

ROTATION
↙

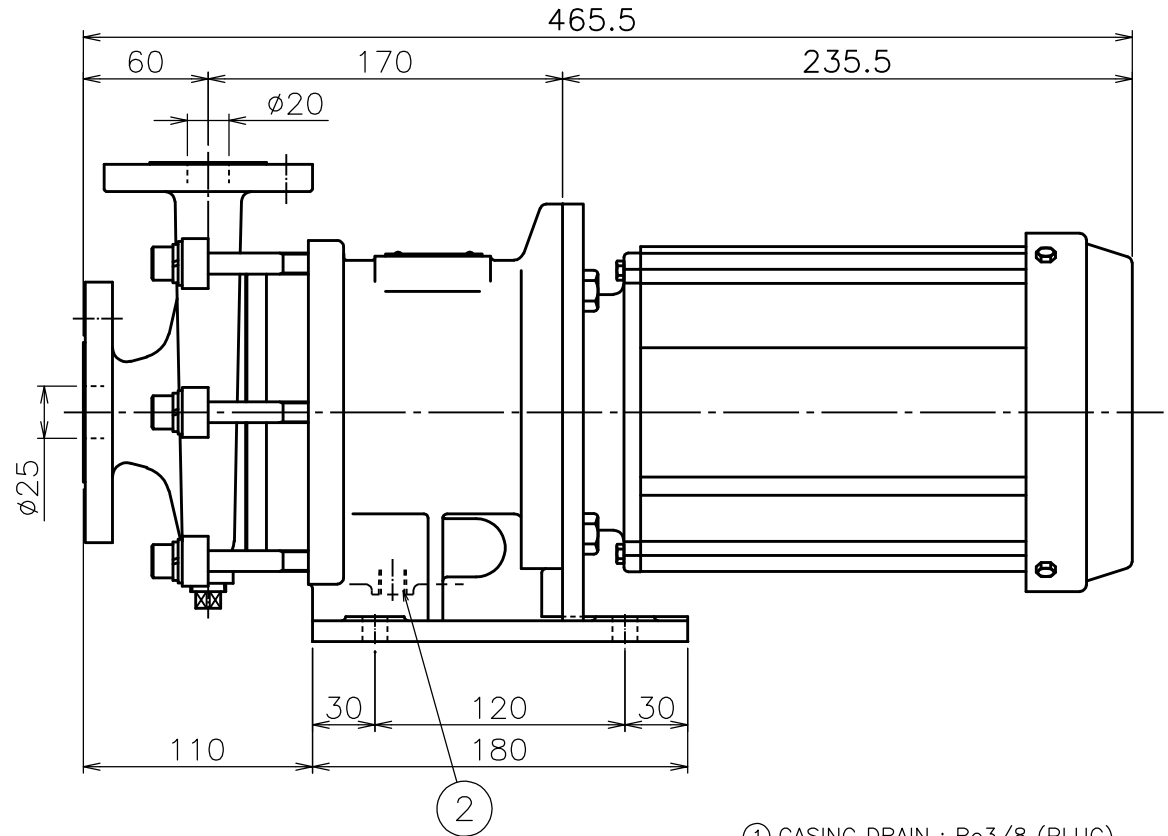

BOLT HOLES
n-øh

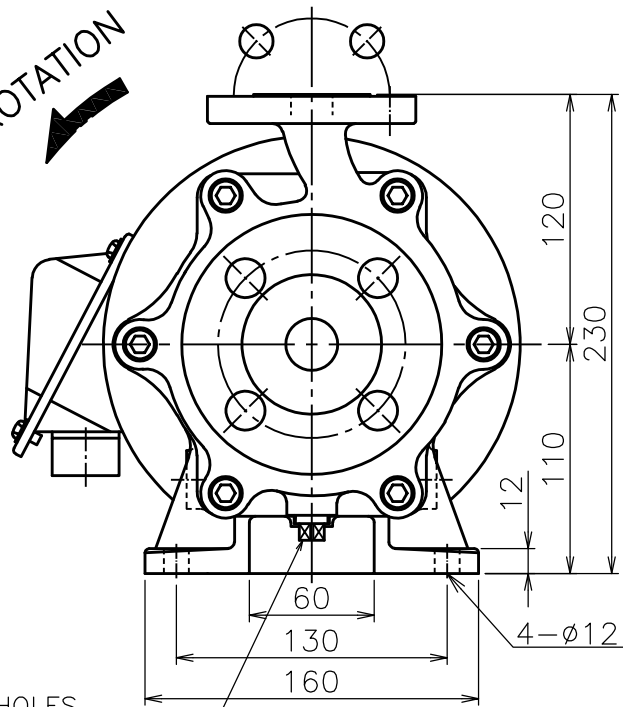
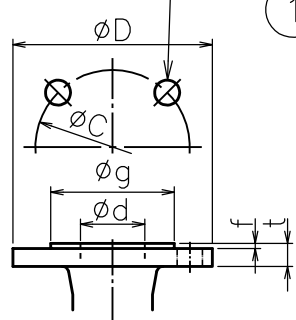

①

②

- ① CASING DRAIN ; Rc3/8 (PLUG)
- ② FRAME ADAPTER DRAIN ; Rc1/4 (OPEN)

MOTOR		MASS APPROX (kg)		
FRAME SIZE	OUTPUT (kW)	PUMP	MOTOR	TOTAL
80M	0.75	23	13.5	36.5

Item No. : _____

Pump Name : _____

FLANGE DIMENSIONS * SMOOTH FINISH (mm)

RATING	SIZE(d)	D	t	f	g	C	n	h	
JIS 10K RF	SUCTION	25mm	125	14	1	67	90	4	19
	DISCHARGE	20mm	100	14	1	56	75	4	15

REV.	△ 2020.4.20 Y.K
	△ 2021.07.07 A.E
APP'D	T.Shimayoshi
CHIEF	M.Murakami
CH'D	S.Okamoto
CH.	A.Endo
DATE	2019.04.09

PUMP CODE
MP220-B54
MAGNETIC DRIVE
CENTRIFUGAL PUMP
OUTLINE DIMENSIONS

WORK No.	
QTY.	
DWG.No.	MP220-B54-X 2
REV.	組 1

3rd ANGLE PROJECTION SCALE \times

SANWA HYDROTECH CORP.

承
審
品
機
組
計

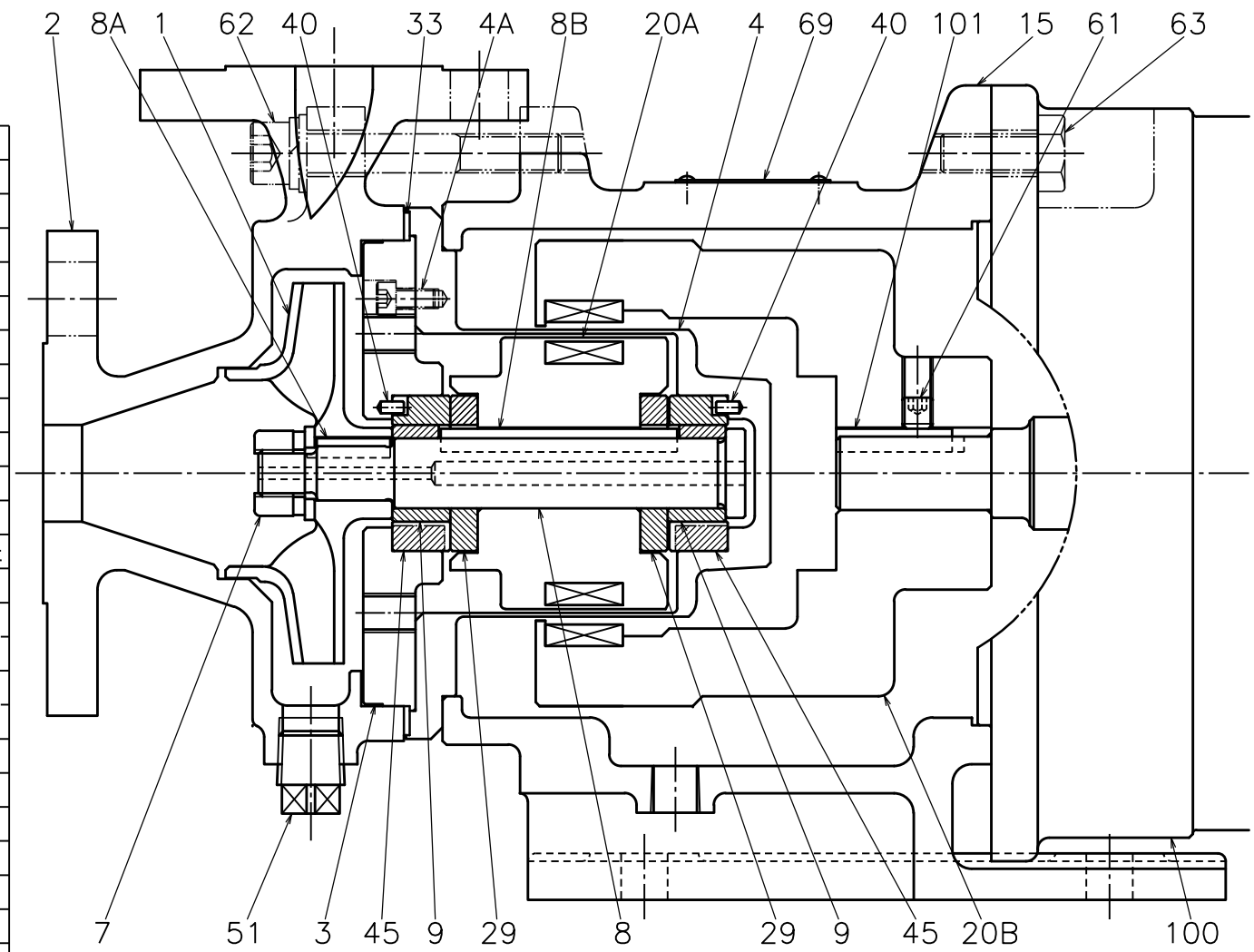

101	COUPLING KEY	-	1		
100	MOTOR	-	1		
69	NAME PLATE	SUS304	1		
63	HEXAGON HEAD BOLT	SUS304	4		
62	HEXAGON SOCKET HEAD CAP SCREW	SUS304	6 ^S		WITH WASHER
61	SET SCREW	SCM435	1		
51	PLUG	SUS304	1		R3/8
45	BUSHING	SiC	2		
40	PIN	SUS316	2		φ3x6L
33	GASKET	PTFE	1		φ120xφ134x1.5t
29	THRUST RING	SiC	2		
	MAGNET	RARE EARTH	1 ^S		
20B	MAGNET COUPLING(M)	FCD	1		K20x6N
	MAGNET	RARE EARTH	1 ^S		
20A	MAGNET COUPLING(P)	SUS304	1		K20N
15	FRAME ADAPTER	FC200	1		
9	SLEEVE	SiC-D	2		
8B	COUPLING KEY	SUS304	1		
8A	IMPELLER KEY	SUS304	1		
8	SHAFT	SUS304	1		
7	IMPELLER NUT	SUS316L	1 ^S		M12, WITH WASHER
4A	HEXAGON SOCKET HEAD CAP SCREW	SUS316L	4		
4	REAR CASING	SUS304	1		
3	CASING COVER	SUS304	1		
2	CASING	SCS13	1		
1	IMPELLER	SCS13	1		

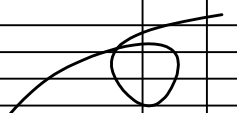
		
NAME OF PART	MAT'L	QTY.
ACCESSORIES		

REV.		
APP'D	H.Miyakoshi	CH. M.Murakami
CHIEF		DWN. M.Murakami
CH'D	M.Murakami	DATE 2019.04.09

PUMP CODE
MP220-B54
MAGNETIC DRIVE
CENTRIFUGAL PUMP

SECTIONAL DRAWING

3rd ANGLE PROJECTION SCALE

SANWA HYDROTECH CORP.

WORK No.	
QTY.	
DWG.No.	MP220-B54-0
REV.	

承認
製品
機組
設計

MARK	NAME OF PART	MAT'L	USE	SPARE	REMARK.
			No.	REQ'D	

PUMP DATA SHEET				WORK No.	
1	CUSTOMER			DATE 2019/6/26	
2	USER			AUTH. BY	CHKD BY MADE BY
3	EQUIP' T NAME			H. Miyakoshi	M. M M. Murakami
4	ORDER No.			REV. DATE	LINE No. BY
5	JOB No.			△1 2020/4/1	25 M. Murakami
6	ITEM (PUMP) No.			△2 2021/7/16	27 Y. Kinoshita
7	PUMP NAME				
8	QUANTITY				
9	OPERATING CONDITIONS			CONSTRUCTION	
10	LIQUID			PUMP CODE	MP220-B54
11	SLURRY			MAGNET TYPE	K20x6N
12		(wt%)	(mm)	BEARING	RADIAL : - THRUST : -
13	PH			AUXILIARY PIPING	-
14	PUMPING TEMP.	(-20~130)	(°C)	NOZZLE	SIZE RATING FACING
15	SPEC. GRAVITY	@P. T.	1	SUCTION	25 (mm) JIS 10K RF
16	VAPOUR PRESS.	@P. T.		DISCHARGE	20 (mm) JIS 10K RF
17	VISCOSITY	@P. T.	1 (mPa · s)	IMPELLER DIA. DES.	φ115 (mm)
18	CAPACITY	4.2 (m3/hr)	70 (l/min)	ROTATION VIEWED FROM CPLG END	■CW □CCW
19	DISCH. PRESS.			PERFORMANCE	
20	SUCT. PRESS.			SPEED	2930 (rpm)
21	DIFF. PRESS.			NPSH REQ'D (WATER)	- (m)
22	TOTAL HEAD	15	(m)	DES. EFF.	32 (%)
23	NPSH AVAIL.			DES. BHP	0.54 (kW)
24	CASE DES. TEMP.	130 (°C)	PRESS. 1.0 (MPaG)	MIN. CONTINUOUS FLOW	0.6 (m3/hr) 10 (l/min)
25	INSTALLATION	<input type="checkbox"/> INDOOR	<input type="checkbox"/> OUTDOOR		
26	MOTOR			MATERIALS	
27	TYPE	IKH3	FORM FCKLAW21E	CASING	SCS13
28				IMPELLER	SCS13
29	SPEED	3000 (SYN)	(rpm)	SLEEVE, BUSHING, THRUST RING	SiC-D, SiC, SiC
30	VOLTS/CYCLE	200 (V)	50 (Hz)	SHAFT (HF)	SUS304 (-)
31	RATED OUTPUT/POLES	0.75 (kW)	2 (P)	GASKET	PTFE
32	FRAME	80M	MFR. TOSHIBA	O RING	---
33	PUMP PAINTING				
34	COLOR BODY:	2.5PB4/10	COVER: ---		
35	REMARKS				
36					
37					
38					
39					
40					



<試験成績表>

CODE : MP220-B54/B56
 PUMP TYPE : MP
 PUMP SIZE : 220

発行日 : 2019.05.13
 Rev.2 : 2021.08.23

規格要目	指定揚液(温度[°C]、比重、粘度)	吐出量(L/min)	全揚程(m)	回転速度(min-1)	原動機出力(kW)	NPSHav/Req(m)
	150/1/1[mPa·s]	70	15	2930	0.75	-/-

計測項目		1	2	3	4	5	6	7	8
回転速度(min-1)		2960	2949	2942	2933	2920			
水温(°C)		2.9	2.9	2.9	2.9	2.9			
吐出量	測定器の読み(L/min)	0.0	26.0	50.6	74.8	110.2			
	吐出量(L/min)	0.0	26.0	50.6	74.8	110.2			
揚程	吐出しヘッド(m)	19.30	18.62	17.84	16.40	12.60			
	吸込ヘッド(m)	1.20	1.20	1.00	0.80	0.30			
	測点高差(m)	0.18	0.18	0.18	0.18	0.18			
	速度ヘッド(m)	0.000	0.045	0.169	0.369	0.801			
	全揚程(m)	18.3	17.6	17.2	16.1	13.3			
理論動力(kW)		0.000	0.075	0.142	0.197	0.239			
周波数(Hz)		50.0	50.0	50.0	50.0	50.0			
電動機	電圧(V)	202.0	201.9	201.8	201.7	201.6			
	電流(A)	1.981	2.133	2.300	2.455	2.655			
	入力(kW)	0.422	0.503	0.582	0.650	0.738			
	効率(%)	78.3	80.0	80.9	81.3	81.4			
	出力(kW)	0.330	0.403	0.471	0.528	0.601			
軸動力(kW) (比重=1)		0.330	0.403	0.471	0.528	0.601			
ポンプ効率(%)		0.0	18.6	30.1	37.3	39.7			
回転換算	吐出量(L/min)								
	全揚程(m)								
	軸動力(kW)								
粘度換算	吐出量(L/min)								
	全揚程(m)								
	軸動力(kW)								
	ポンプ効率(%)								
	マグネットポンプ効率(%)								

附属試験用	電動機要目
形式	IKH3-FCKLAW21E
出力	(0.75 kW)
周波数(Hz)	(50 Hz)
電圧	(200 V)
電流	(3.2 A)
極数	(2 P)
回転速度	(2870min-1)
製造番号	62140799
製造業者名	TOSHIBA
試験揚液	常温清水
吐出量測定方法	電磁流量計
室温	(3 °C)
連続運転時間	(60 min)
軸受温度	
軸継手側	(- °C)
反対側	(- °C)
インペラー径	(115 mm)
マグネット形式	K20x6N-80
キャンロス	(0.14 kW)
備考	
試験者名	足立
製造業者名	三和ハイドロテック(株)

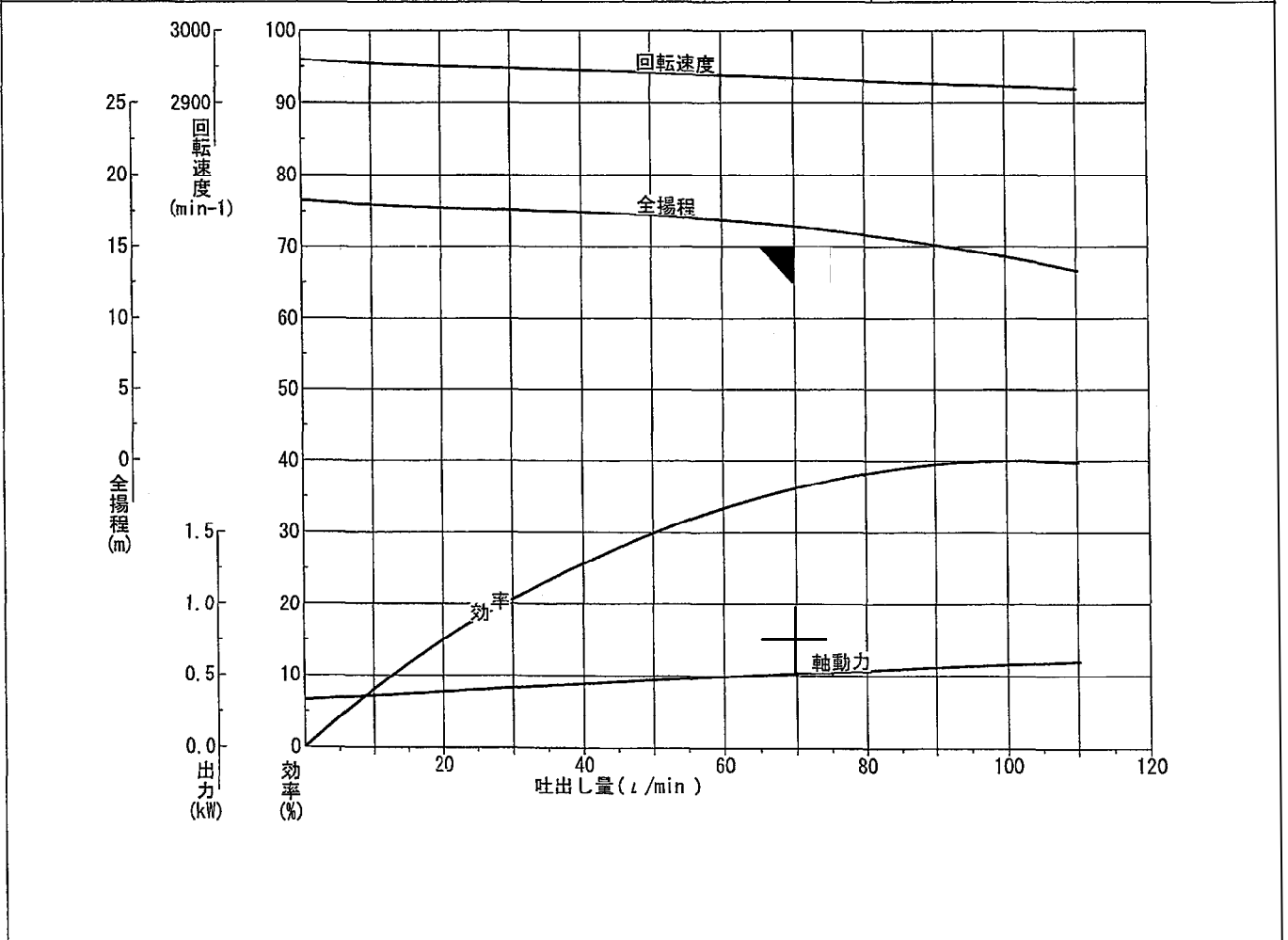

3HDA009211

図面番号 DRAWING NO.

REVISION MARK

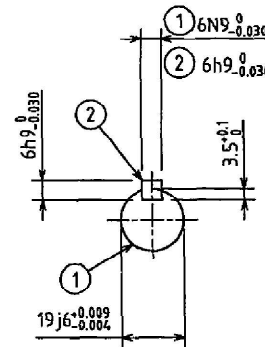
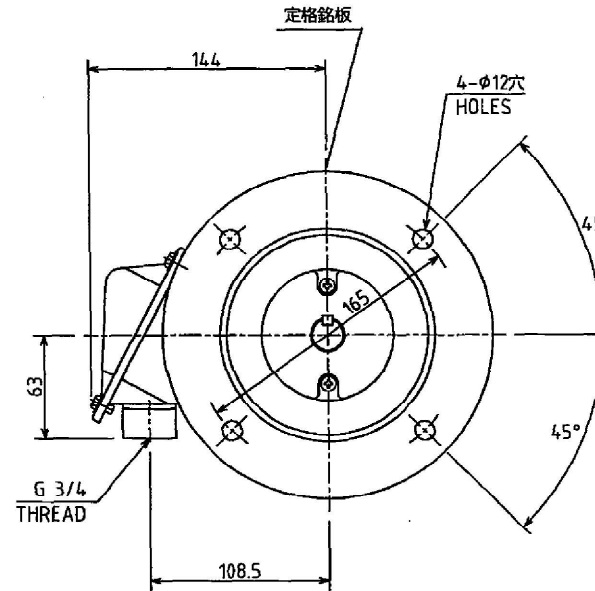
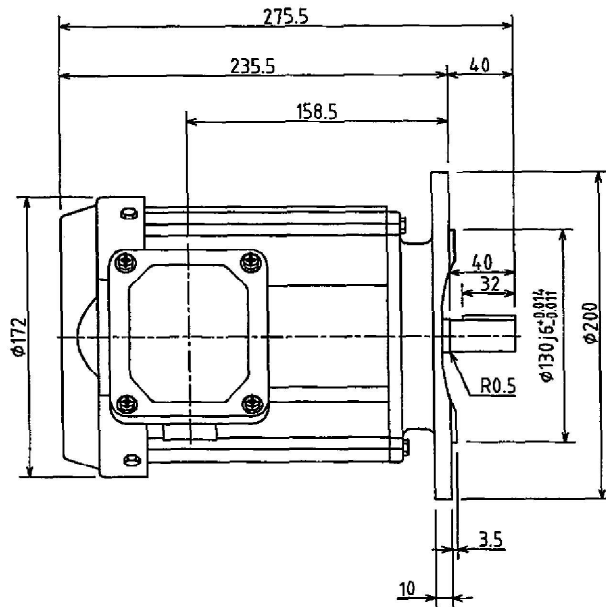

マンセル3.74BG3.04/1.25近似色(深緑)

保護方式 PROTECTION
IP55

出力 OUTPUT 0.75 kW	極数 POLES 2	電圧 VOLTS 200/200/220 V	周波数 FREQ. 50/60/60 Hz	回転速度 FULL LOAD SPEED 2870/3445/3480 min ⁻¹	軸受 BEARING 負荷側 LOAD SIDE 6204ZZC3 反負荷側 OPPL.SIDE 6204ZZC3	概略質量 APPROX. MASS 本体 MOTOR 13.5 kg
形 TYPE IKH3	式 FORM FCKLAW21E	耐熱クラス THERMAL CLASS 155(F)	定格 RATING S1	枠番号 FRAME 80M	フランジ番号 FLANGE FF165	

記号 MARK	承認 APPROVED BY T.FURUICHI Dec. 26 '19 設計 DESIGNED BY N.INAMURA Dec. 26 '19 製図 DRAWN BY Y.HIROTA Dec. 26 '19	検図 CHECKED BY R.KATSUKI Dec. 26 '19 製図 DRAWN BY Y.HIROTA Dec. 26 '19	名称 TITLE 三相誘導電動機外形図 OUTLINE FOR THREE PHASE INDUCTION MOTOR
年月日 DATE			
承認 APPROVED BY			
変更者 REVISED BY			
記事 CONTENTS	単位 UNITS mm		
保管 REGISTERED	TOSHIBA 東芝産業機器システム株式会社 TOSHIBA INDUSTRIAL PRODUCTS AND SYSTEMS CORPORATION		図面番号 DRAWING NO. 3HDA009211

REV. MARK

保管 REGISTERED M

配布先 PRESENT TO

3HDZ000011

REV. MARK
②

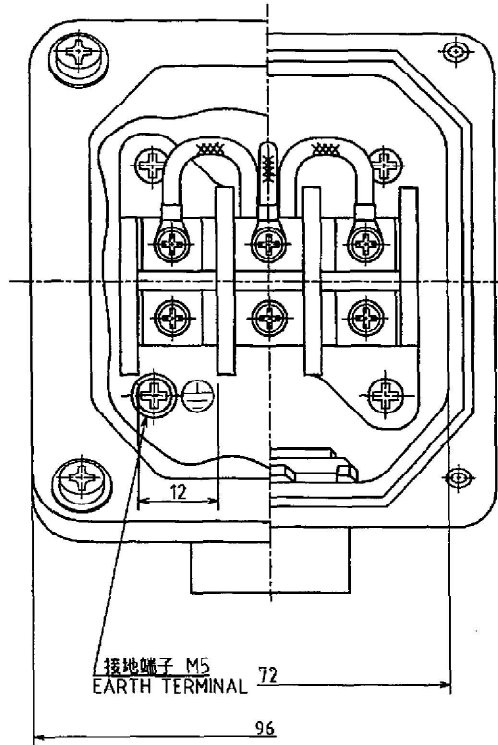
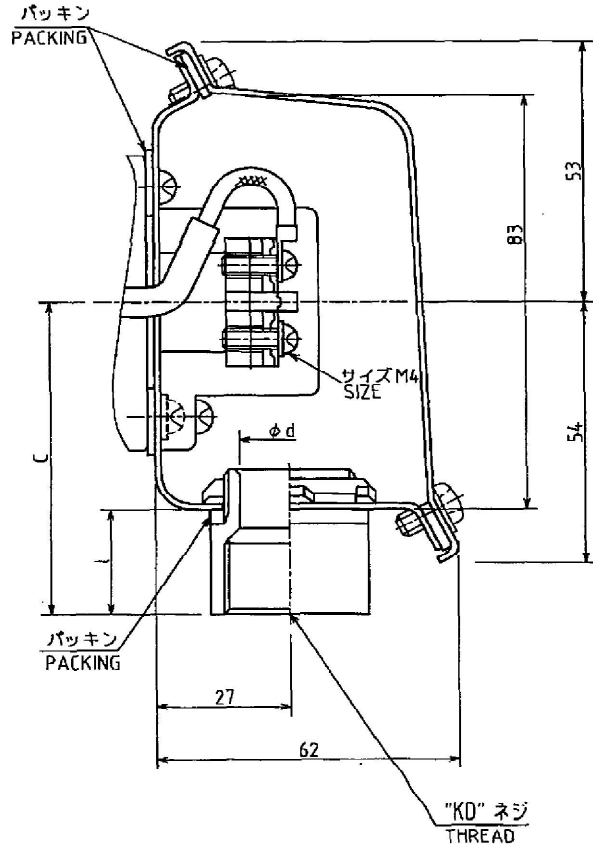

PNNo.	KD	C	l	d
1	G1	65	23	25
2	G $\frac{3}{4}$	63	21	20
3	G $\frac{1}{2}$	63	21	15

適用枠番号 63M ~ 112M
FRAME NO.

	②	①	記号MARK
	Feb. 14. 17	Aug. 10. 16	年月DATE
	T.FURUICHI	T.FURUICHI	承認APPROVED BY
	S.TAKAHASHI	S.ASAI	変更者REVISED BY
	CHG. COMPANY NAME.	ADD PNO.	
			記本CONTENTS
			保管REGISTERED

 尺貫 SCALE N.T.S. 単位 UNITS mm	承認 APPROVED BY T.FURUICHI Dec. 4. 12	検図 CHECKED BY N.TOJIMA Dec. 4. 12	名称 TITLE 端子箱詳細図 CONSTRUCTION OF TERMINAL BOX 鋼板製 63M~112M 屋外形 図面番号 DRAWING NO. 3HDZ000011 変更記号 ②
	設計 DESIGNED BY M.OGAWA Dec. 4. 12	製図 DRAWN BY S.MATSUBARA Dec. 4. 12	
	TOSHIBA 東芝産業機器システム株式会社 TOSHIBA INDUSTRIAL PRODUCTS AND SYSTEMS CORPORATION		
	保管 REGISTERED		

保管 REGISTERED M
