

PUMP DATA SHEET				WORK No.	
1	CUSTOMER			DATE 2020/4/1	
2	USER			AUTH. BY	CHKD BY MADE BY
3	EQUIP' T NAME			T. Shimayoshi	M. M M. Murakami
4	ORDER No.			REV. DATE	LINE No. BY
5	JOB No.			\triangle 2021/7/16	27 Y. Kinoshita
6	ITEM (PUMP) No.				
7	PUMP NAME				
8	QUANTITY				
9	OPERATING CONDITIONS			CONSTRUCTION	
10	LIQUID			PUMP CODE	MMP11-B66
11	SLURRY			MAGNET TYPE	R25x6N
12	(wt%)	(mm)		BEARING RADIAL :	- THRUST : -
13	PH			AUXILIARY PIPING	-
14	PUMPING TEMP.	(-20~150)	(°C)	NOZZLE	SIZE RATING FACING
15	SPEC. GRAVITY	@P. T.	1	SUCTION	1/2" R -
16	VAPOUR PRESS.	@P. T.		DISCHARGE	1/2" R -
17	VISCOSITY	@P. T.	1 (mPa · s)	IMPELLER DIA. DES.	ϕ 93 (mm)
18	CAPACITY	1.44 (m3/hr)	24 (l/min)	ROTATION VIEWED FROM CPLG END	<input checked="" type="checkbox"/> CW <input type="checkbox"/> CCW
19	DISCH. PRESS.		(MPaG)	PERFORMANCE	
20	SUCT. PRESS.		(MPaG)	SPEED	3520 (rpm)
21	DIFF. PRESS.		(MPa)	NPSH REQ' D(WATER)	- (m)
22	TOTAL HEAD	15	(m)	DES. EFF.	25 (%)
23	NPSH AVAIL.		(m)	DES. BHP	0.24 (kW)
24	CASE DES. TEMP.	150 (°C)	PRESS. 0.6 (MPaG)	MIN. CONTINUOUS FLOW	0.18 (m3/hr) 3 (l/min)
25	INSTALLATION	<input type="checkbox"/> INDOOR	<input type="checkbox"/> OUTDOOR		
26	MOTOR			MATERIALS	
27	TYPE	IK FORM	FCKLAW21E	CASING	SCS14
28				IMPELLER	SUS316
29	SPEED	3600 (SYN)	(rpm)	BUSHING, THRUST RING	SiC-D, SiC
30	VOLTS/CYCLE	200 (V)	60 (Hz)	SHAFT (HF)	SiC (-)
31	RATED OUTPUT/POLES	0.4 (kW)	2 (P)	GASKET	---
32	FRAME	71 MFR.	TOSHIBA	O RING	PTFE
33	PUMP PAINTING				
34	COLOR BODY :	2.5PB4/10	COVER :	---	
35	REMARKS				
36					
37					
38					
39					
40					



<試験成績表>

発行日: 2019.05.13
Rev.1 : 2020.04.01
Rev.2 : 2022.03.08

CODE : MMP11-B64/B66
PUMP TYPE : MMP
PUMP SIZE : 11

規格要目	指定揚液(温度[°C]、比重、粘度) 25/1/1[mPa·s]	吐出量(L/min)	24	全揚程(m)	15	回転速度(min-1)	3520	原動機出力(kW)	0.40	NPSH _{Av} /Req(m)	-/-
------	-------------------------------------	------------	----	--------	----	-------------	------	-----------	------	----------------------------	-----

計測項目		1	2	3	4	5	6	7	8
回転速度 (min-1)		3531	3517	3505	3497	3488			
水温 (°C)		23.1	23.1	23.1	23.1	23.1			
吐出量	測定器の読み(L/min)	0.0	12.0	25.0	32.0	40.0			
	吐出し量(L/min)	0.0	12.0	25.0	32.0	40.0			
揚程	吐出しヘッド(m)	19.0	18.2	15.9	14.7	12.7			
	吸込ヘッド(m)	0.44	0.43	0.37	0.33	0.28			
	測点高差(m)	0.00	0.00	0.00	0.00	0.00			
	速度ヘッド(m)	0.000	0.000	0.000	0.000	0.000			
	全揚程(m)	18.6	17.8	15.5	14.4	12.4			
理論動力(kW)		0.000	0.035	0.063	0.075	0.081			
周波数(Hz)		60.0	60.0	60.0	60.0	60.0			
電動機	電圧(V)	200.2	200.3	200.4	200.3	200.3			
	電流(A)	0.942	1.020	1.130	1.180	1.220			
	入力(kW)	0.206	0.244	0.285	0.306	0.329			
	効率(%)	70.2	73.2	75.1	75.7	76.2			
	出力(kW)	0.145	0.179	0.214	0.232	0.251			
軸動力(kW) (比重=1)		0.145	0.179	0.214	0.232	0.251			
ポンプ効率(%)		0.0	19.5	29.6	32.4	32.3			
回転換算	吐出し量(L/min)								
	全揚程(m)								
	軸動力(kW)								
粘度換算	吐出し量(L/min)								
	全揚程(m)								
	軸動力(kW)								
	ポンプ効率(%)								
	マグネットポンプ効率(%)								

電動機要目	
形式	IK-FCKLAW21E
出力	(0.4 kW)
周波数(Hz)	(60 Hz)
電圧	(200 V)
電流	(1.8 A)
極数	(2 P)
回転速度	(3350min-1)
製造番号	21040093898
製造業者名	TOSHIBA
試験揚液	常温清水
吐出量測定方法	電磁流量計
室温	(22 °C)
連続運転時間	(60 min)
軸受温度	
軸継手側	(- °C)
反対側	(- °C)
インペラー径	(93 mm)
マグネット形式	R25x6N-71
キャンロス	(0.050 kW)
備考	

試験者名 杉山
製造業者名 三和ハイドロテック(株)

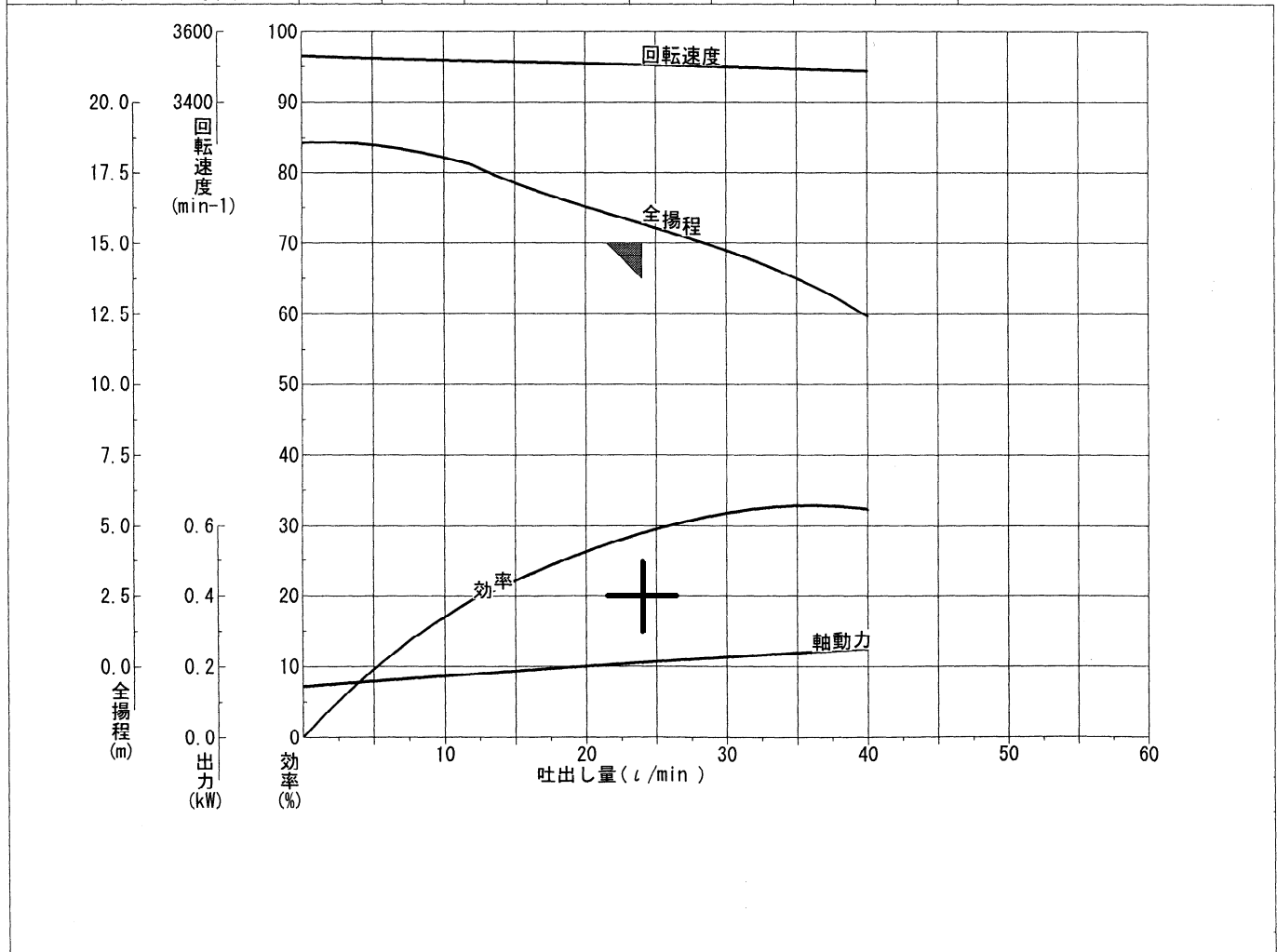

3HDB000111
 図面番号 DRAWING NO.
 REV. MARK

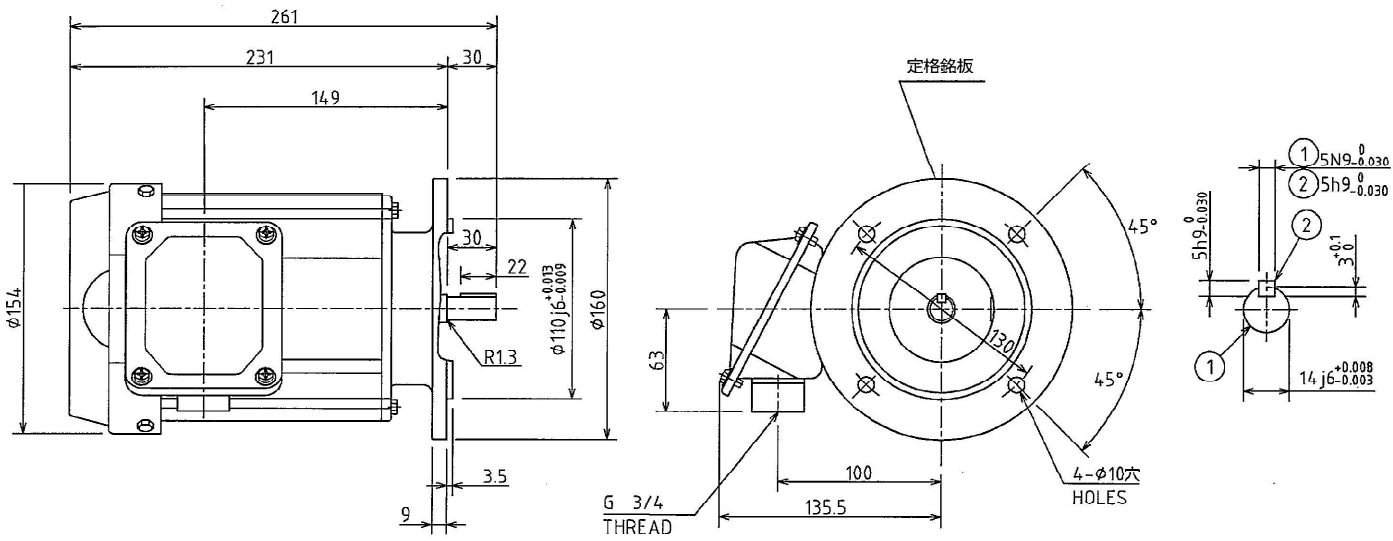

マンセル3.74BG3.04/1.25近似色(深緑)

							保護方式 PROTECTION IP44
出力 OUTPUT 0.4 kW	極数 POLES 2	電圧 VOLTS 200/200/220 V	周波数 FREQ. 50/60/60 Hz	回転速度 FULL LOAD SPEED 2800/3350/3400 min ⁻¹	軸受 BEARING 負荷側 LOAD SIDE 6203ZZC3 反負荷側 OPP.L.SIDE 6203ZZC3	概略質量 APPROX. MASS 本体 MOTOR 9.5 kg	
形 TYPE IK	式 FORM FCKLAW21E	耐熱クラス THERMAL CLASS 120(E)	定格 RATING S1	枠番号 FRAME 71M	フランジ番号 FLANGE FF130		
記号 MARK 年月日 DATE		承認 APPROVED BY T.FURUICHI Dec. '16 '19	検図 CHECKED BY R.KATSUKI Dec. '16 '19	名称 TITLE 三相誘導電動機外形図 OUTLINE FOR THREE PHASE INDUCTION MOTOR			
承認 APPROVED BY				尺度 SCALE N.T.S.	設計 DESIGNED BY N.INAMURA Dec. '14 '19	製図 DRAWN BY M.YOSHIKADO Dec. '14 '19	
変更者 REVISED BY		単位 UNITS mm					
記事 CONTENTS		変更 REVISIONS	TOSHIBA 東芝産業機器システム株式会社 TOSHIBA INDUSTRIAL PRODUCTS AND SYSTEMS CORPORATION			図面番号 DRAWING NO. 3HDB000111	
保管 REGISTERED						REV. MARK 変更記号	

REF.M7310194,3HDA004420,3HDB000104

保管 REGISTERED M

配布先 PRESENT TO
7 8 CAD-AC

3HDZ000011

REV. MARK
②

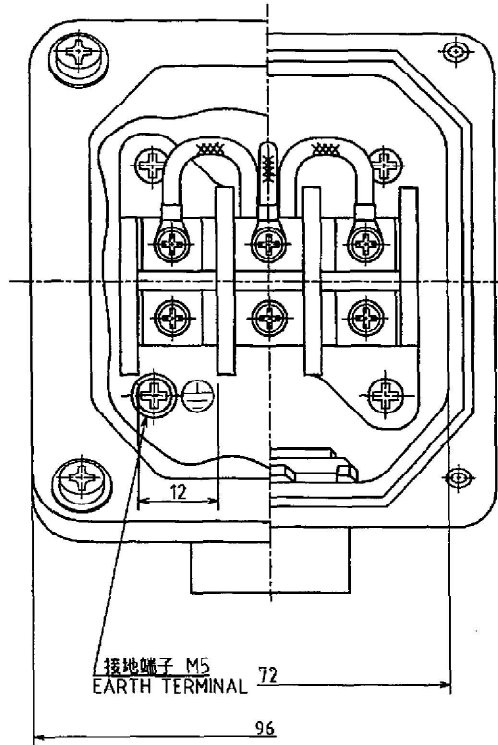
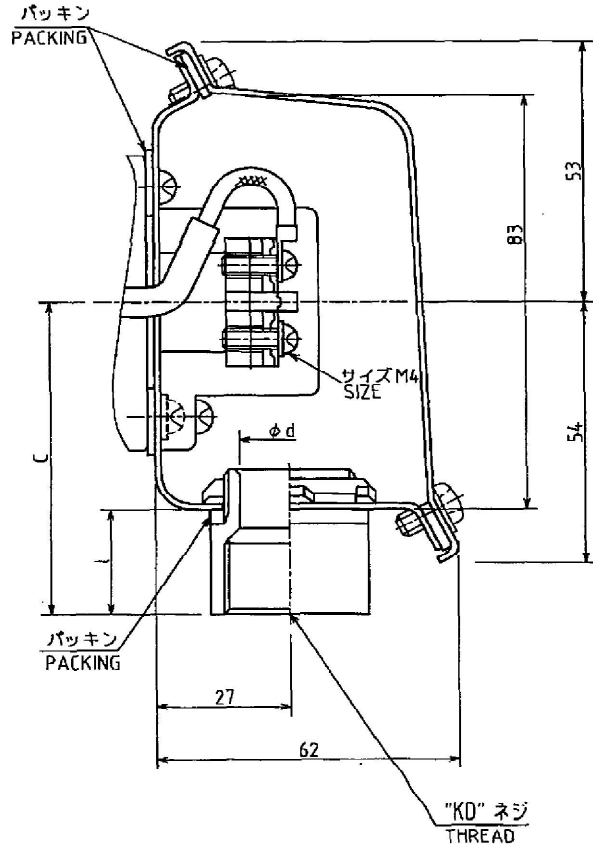

PNNo.	KD	C	l	d
1	G1	65	23	25
2	$G\frac{3}{4}$	63	21	20
3	$G\frac{1}{2}$	63	21	15

適用枠番号 63M ~ 112M
FRAME NO.

	②	①	記号MARK
	Feb. 14. 17	Aug. 10. 16	年月DATE
	T.FURUICHI	T.FURUICHI	承認APPROVED BY
	S.TAKAHASHI	S.ASAI	変更者REVISED BY
	CHG. COMPANY NAME.	ADD PNO.	
			記本CONTENTS
			保管REGISTERED

 尺貫 SCALE N.T.S. 単位 UNITS mm	承認 APPROVED BY T.FURUICHI Dec. 4. 12	検図 CHECKED BY N.TOJIMA Dec. 4. 12
	設計 DESIGNED BY M.OGAWA Dec. 4. 12	製図 DRAWN BY S.MATSUBARA Dec. 4. 12
	TOSHIBA 東芝産業機器システム株式会社 TOSHIBA INDUSTRIAL PRODUCTS AND SYSTEMS CORPORATION	
	保管 REGISTERED	

名称 TITLE 端子箱詳細図 CONSTRUCTION OF TERMINAL BOX
鋼板製 63M~112M 屋外形
図面番号 DRAWING NO. 3HDZ000011
REV. MARK ②